

YoungTek Electronics Corp.

Company Profile

Welcome

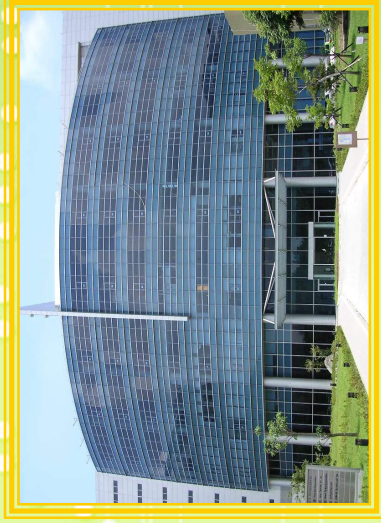

Welcome

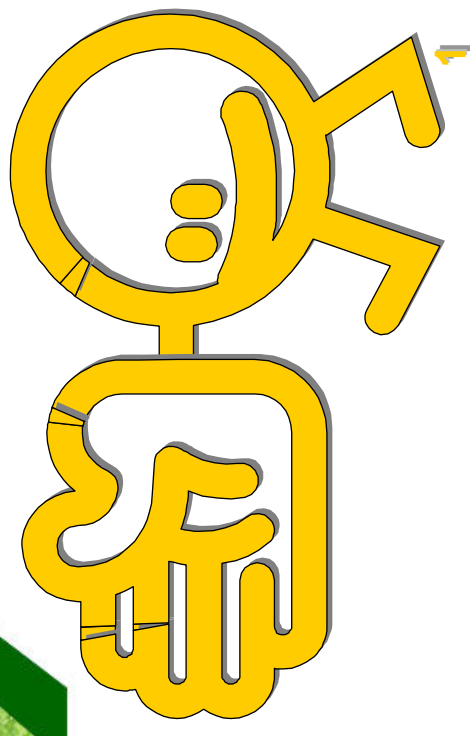

YoungTek Electronics Corp.

Company Profile

Brief Introduction

Date : 9 September, 2010



YoungTek Electronics Corp.

Contents

Company Profile

- **Brief Introduction**
- **Factory Overview**
- **Company Milestone**
- **Company Management Concept**
- **OEM Services**
- **Own Product Development**
- **Revenue Growth & Business Expansion Review**
- **Company Mission**



Brief Introduction

Company Profile

Found Time : 1991/July

Chairman : Bily Wang

President of Service Group : Jeff Chang

President of Own Product Group : Glen Chen

Employees : 916

Capital : NTD 946 million (USD 29.8 million)

Address : Plant 1(1F~5F) : Special & substrate sawing

An Ping Plant (3F) : LED sorting

Li Hsin Plant (2F~3F) : LED back-end turn-key service

SBIP Plant (1~4F、7F) : IC back-end turn-key service, ATE&AOI

Business Items :

- Semiconductor and LED OEMs**: Wafer sawing, grinding, sorting and IC testing, LED testing, laser scribing, sorting and substrate sawing.
- Design, manufacture and sales of semiconductor equipments**: CIS/CCM equipments, AOI system, full-function IC tester, logic IC tester, analog IC tester, Mixed-Signal IC Tester , LED tester, prober and sorter.

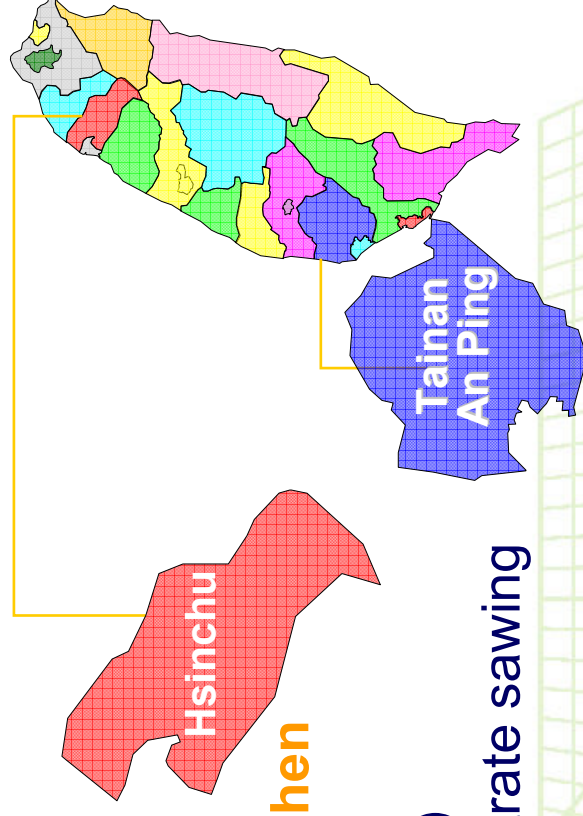

Factory Overview

Company Profile

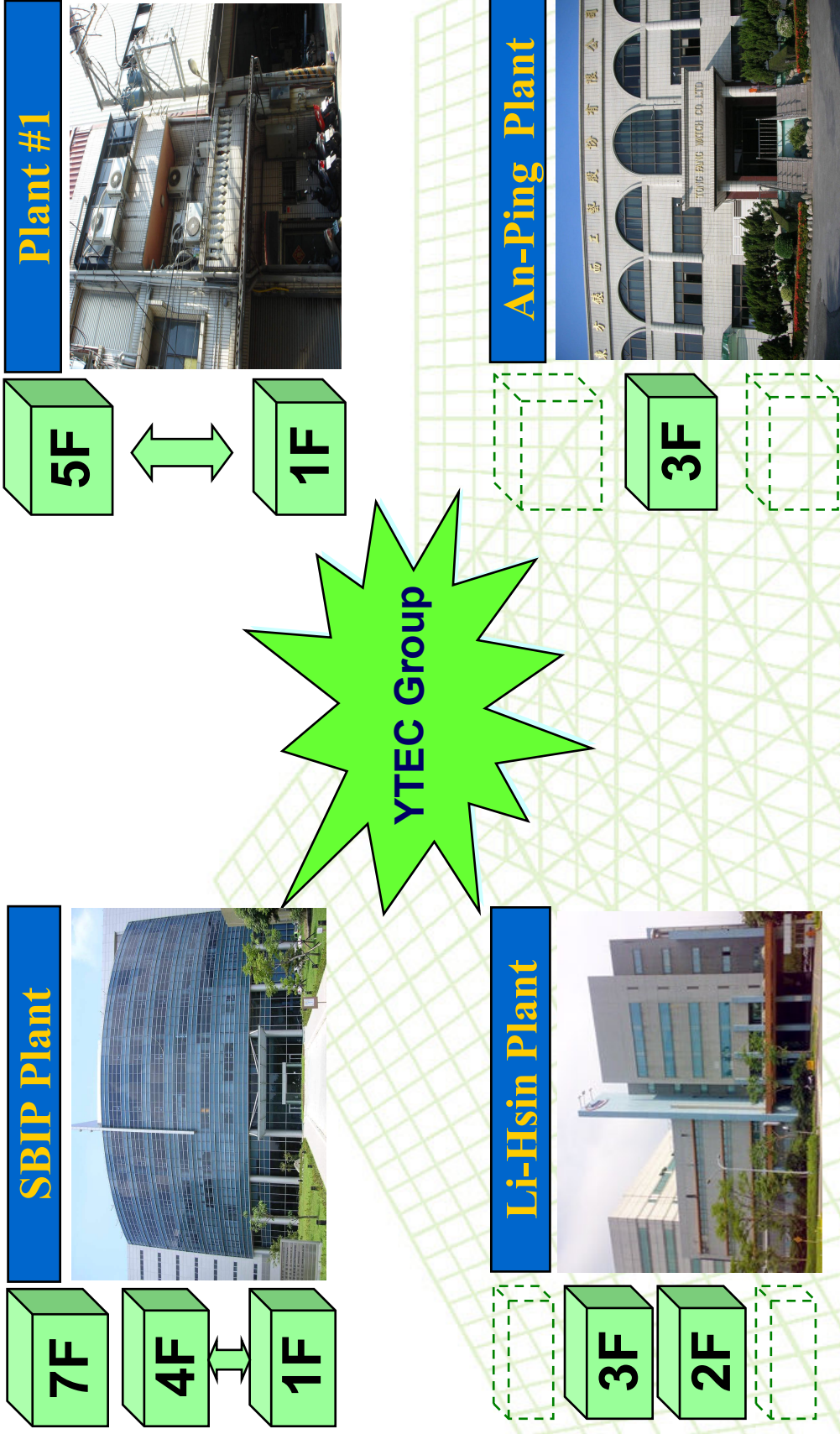

Company Milestone

Company Profile

- 1991/Jul. YTEC was founded and the capital is NTD \$ 5 million.
- 1998/Oct. Develop logic tester (Goblin) with 5 MHz/40 pins.
- 2000/Mar. Achieved the certification of ISO 9001
- 2000/Jul. Full-function IC tester was verified by industry agency with predominant product development project.
- 2002/Aug. SEC (Securities and Exchange Commission) approve YTEC to public stock.
- 2003/Nov. LED OEM service was established.
- 2003/Dec. Obtain OTC certification.
- 2004/Mar. Got the approval to establish the branch in Hsin chu SBIP.
- 2004/Mar.29 Listed in Taiwan stock exchange. (Stock No.: 6261)
- 2006/Dec. Achieved the certification of ISO 14001 and OHSAS 18001.
- 2007/Jul. Develop Tainan An Ping plant for LED sorting.
- 2007/Nov. Build up AOI key technologies and business.
- 2008/May Develop Li Hsin plant for LED test & sorting.
- 2008/Otc. Achieved the certification of ISO/TS 16949.
- 2009/Jun. Solar silicon substrate inspection system was verified by Science Park Administration with development project.
- 2010/Mar. Develop SBIP plant for wafer grinding & sawing.



Company Management Concept

Company Profile

經營理念：(Management Concept)

主人翁經營理念；下工程即是客戶。

Treat YTEC as your own company. (Host concept)

Treat all post projects and processes as our customers.

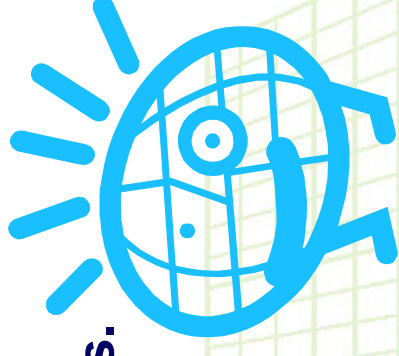

工作態度：(Working Attitude)

成功者找方法；失敗者找藉口。

A successful person will find the way to overcome a challenge

Loser finds excuses.



IC OEM Services

Company Profile

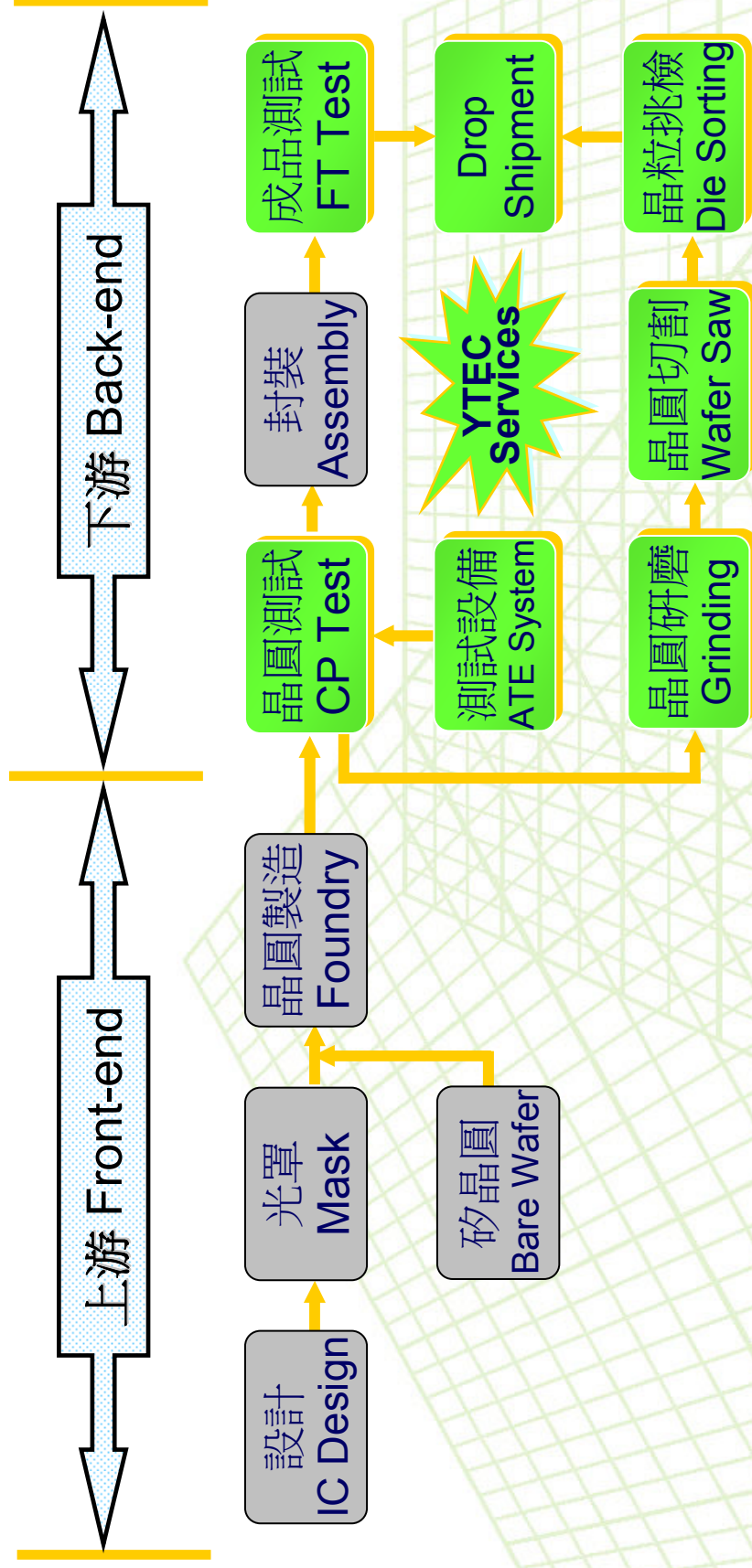

YoungTek Electronics Corp.

專業測試代工服務(IC Testing OEM)

Company Profile

- ❑ 4"~12" Wafer testing (CP)、Test program and test kit development (Probe-card design and manufacture).
- ❑ IC packaging testing (FT)、Package type : DIPs、T/SOPs、L/QFPs、QFN、L/BGA...
- ❑ PC peripheral product、Logic、Analog、Mixed-signal、No-volatile memory、MCU、LCD driver IC、High speed/ High pin count (Scud-1A 512C) testing.
- ❑ CIS(CMOS Image Sensor)、RF、SoC product testing
- ❑ Others : Laser trimming、Lead scanning、Test program and test kit development technical support **Turn-key service** (For example: PKG assembly、Tape-reel、Drop-shipment...).

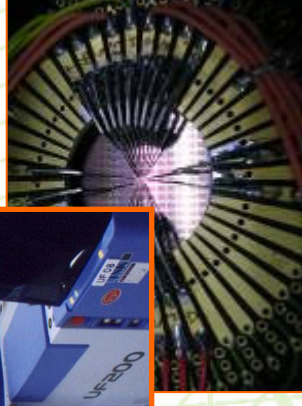
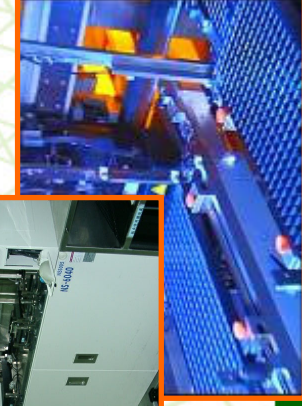
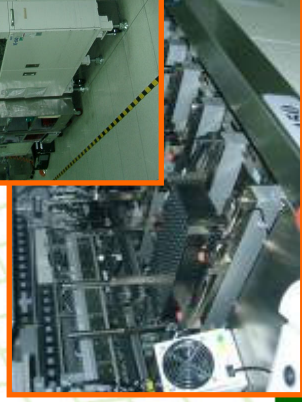
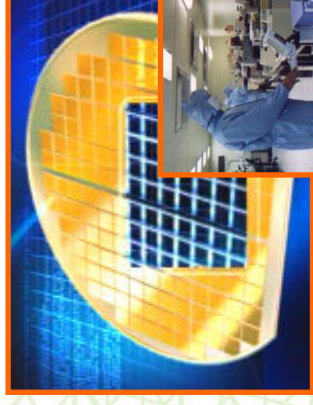
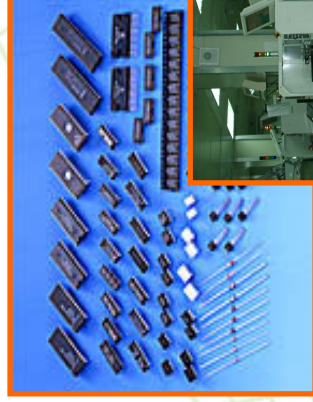

研磨、切割及挑檢代工服務

(Grinding, Sawing, P&P Service)

Company Profile

□ Service Items:

Wafer back-side grinding sawing chip pick & place services for Consumer and gold bump products.

Process	Back-side Grinding	Sawing	Pick & Place
Environment	 <p>Class 1K</p>	 <p>Class 1K</p>	 <p>Class 100</p>
Capability	<ul style="list-style-type: none"> ● 4"~12" Wafer Back-side Grinding ● 8"~12" Wafer Polish Solution ● Wafer TTV $\leq 5 \mu\text{m}$ ● Chip TTV $\leq 2 \mu\text{m}$ 	<ul style="list-style-type: none"> ● 4"~12" Wafer Sawing ● Dual Cutting Function ● High-pressure & Atomizing Cleaning System (二流體清洗裝置) ● Dust Collecting System 	<ul style="list-style-type: none"> ● 4"~12" Wafer Pick & Place ● Map and Ink Pick & Place Solution ● Chip Back-side AOI Inspection System



LED OEM Services

Company Profile

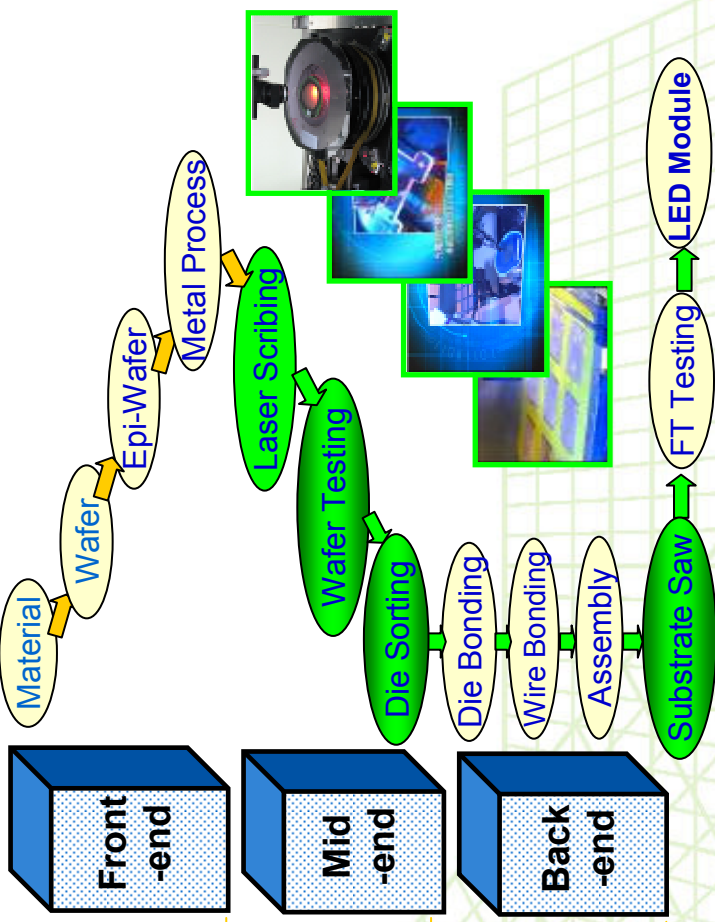
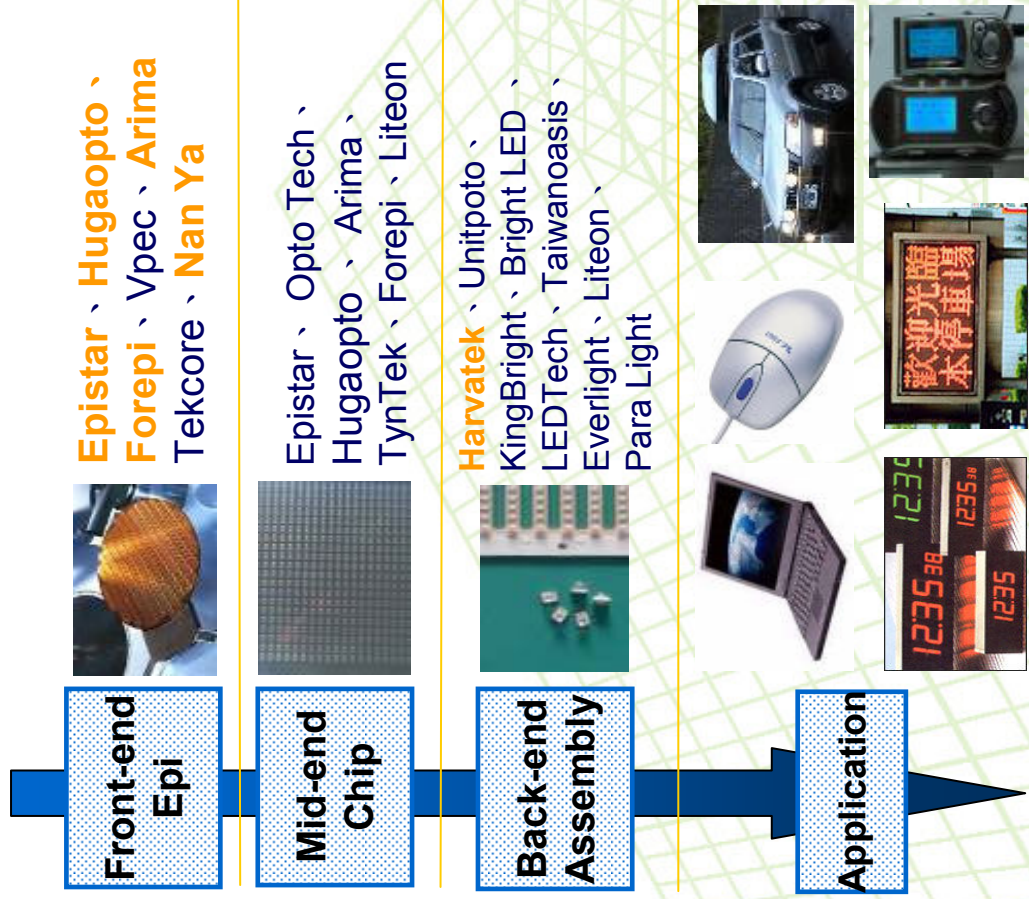

- **Front-end Product** : Wafer, Epi-Wafer, For example GaAs, GaAsP, AlGaAs, AlGaInP
- **Mid-end Product** : Laser Scribing, Wafer Testing and Pick & Place Die-sorting
- **Back-end Product** : Lamp, Display, SMD, IR transmission module, Optical Communication product, Substrate Saw



YoungTek Electronics Corp.



Company Profile

Own Product Development



YTEC YoungTek Electronics Corp.

Own Product Development

Company Profile

- Scud-1A 512C full-function IC Tester
- CIS(CMOS Image Sensor System)
CMOS影像感測系統
- HV LED Tester
- CCM (CMOS/Compact Camera Module)
影像感測模組測試設備
- AOI (Auto optical Inspection)
自動光學檢測系統

CIS(CMOS Image Sensor) IC Tester

Company Profile

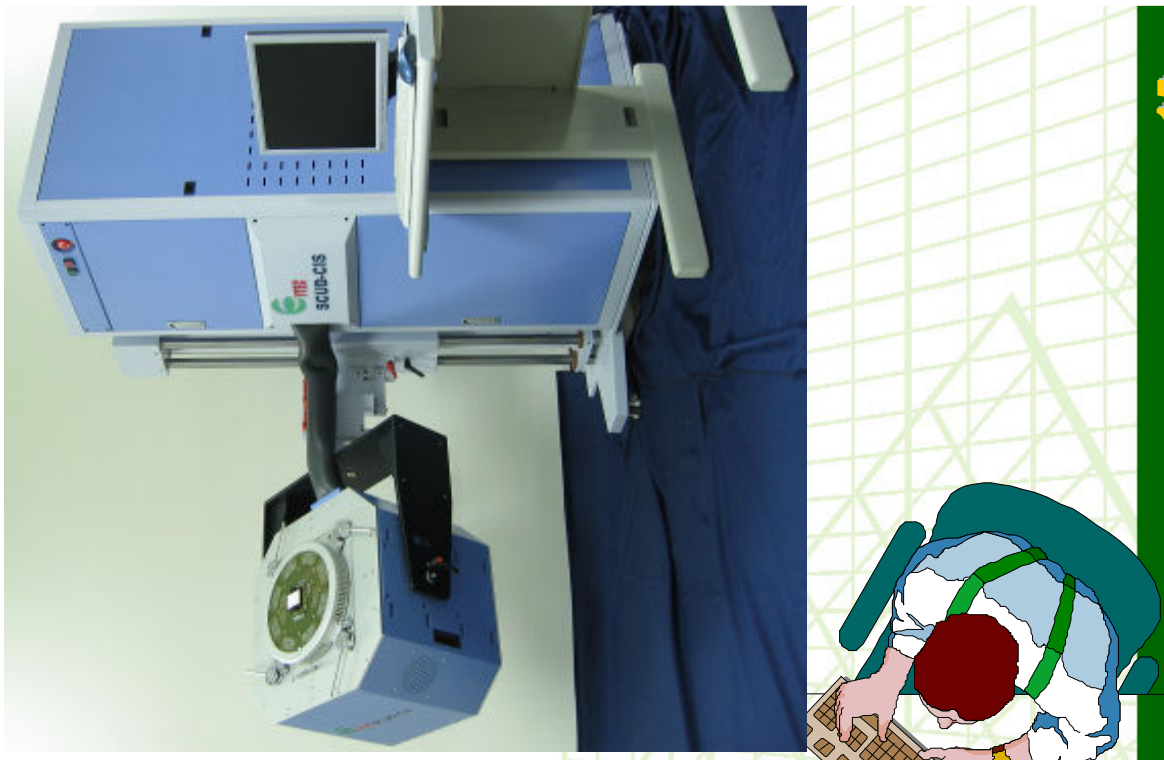
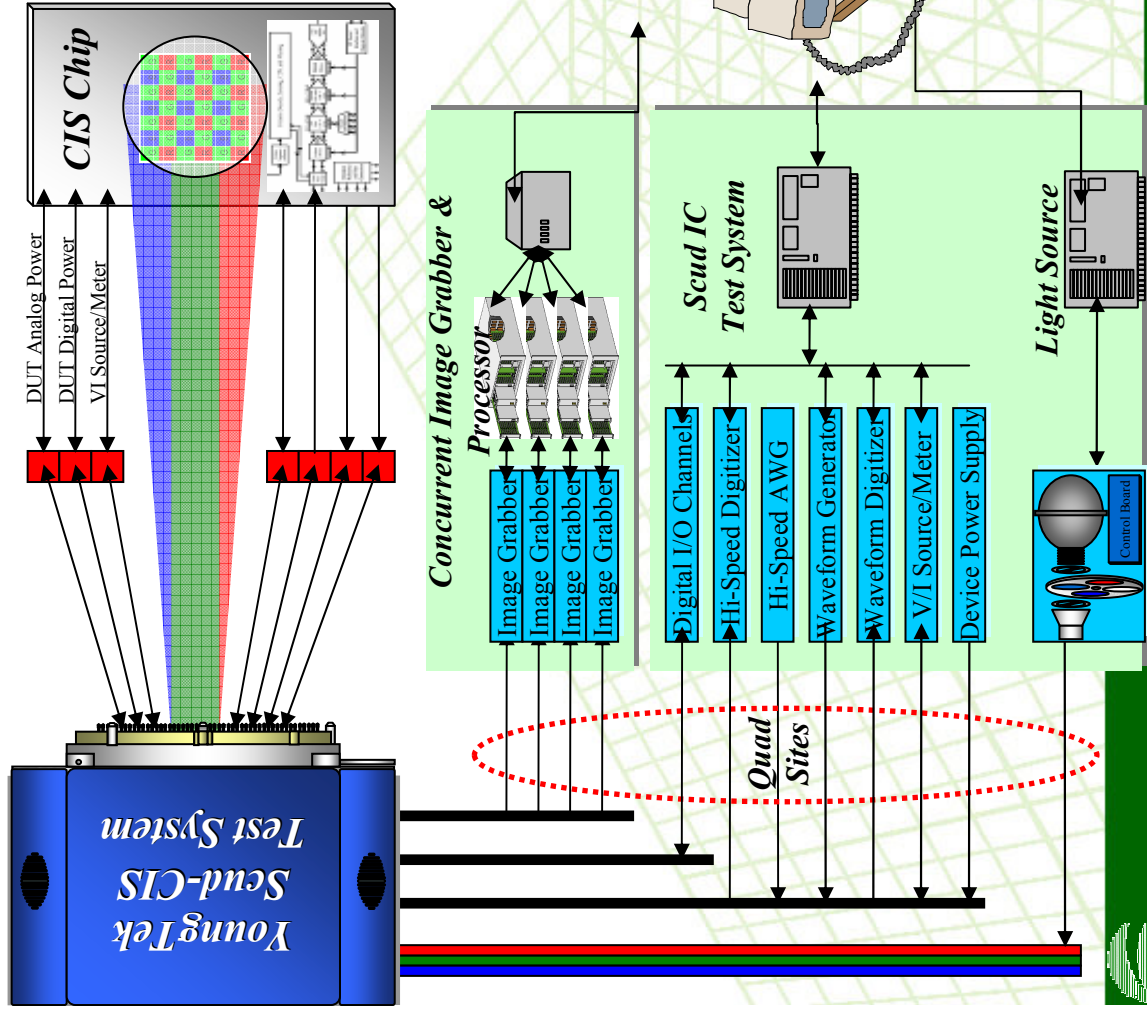

HV LED Tester

Company Profile

□ YTSD01 → YTSD02 → YTEC 8000 HV LED Tester

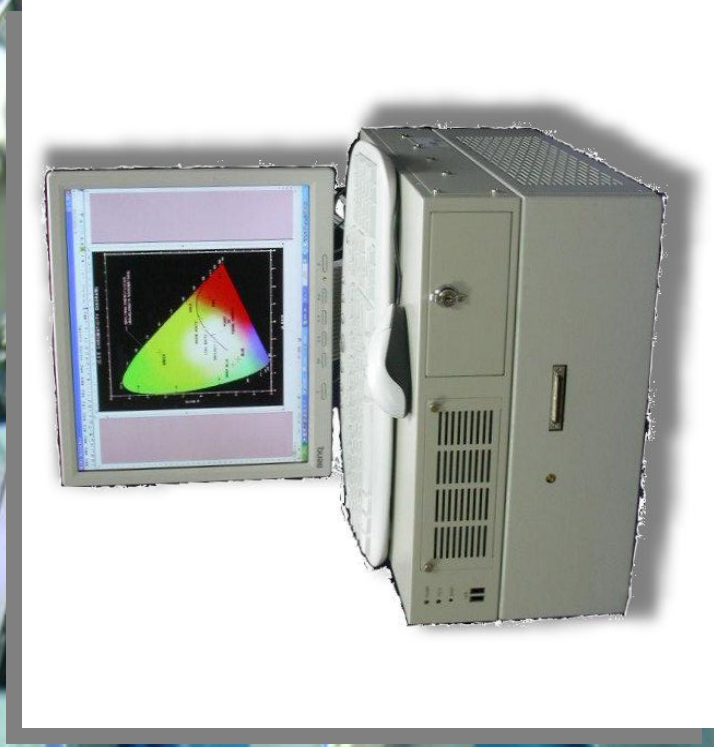

YTEC YoungTek Electronics Corp.

CCM(CMOS/Compact Camera Module)

Company Profile

CCM Test System YT3100



Fully Auto CCM Test System YT3300



CIS IC /CCM Application

Company Profile

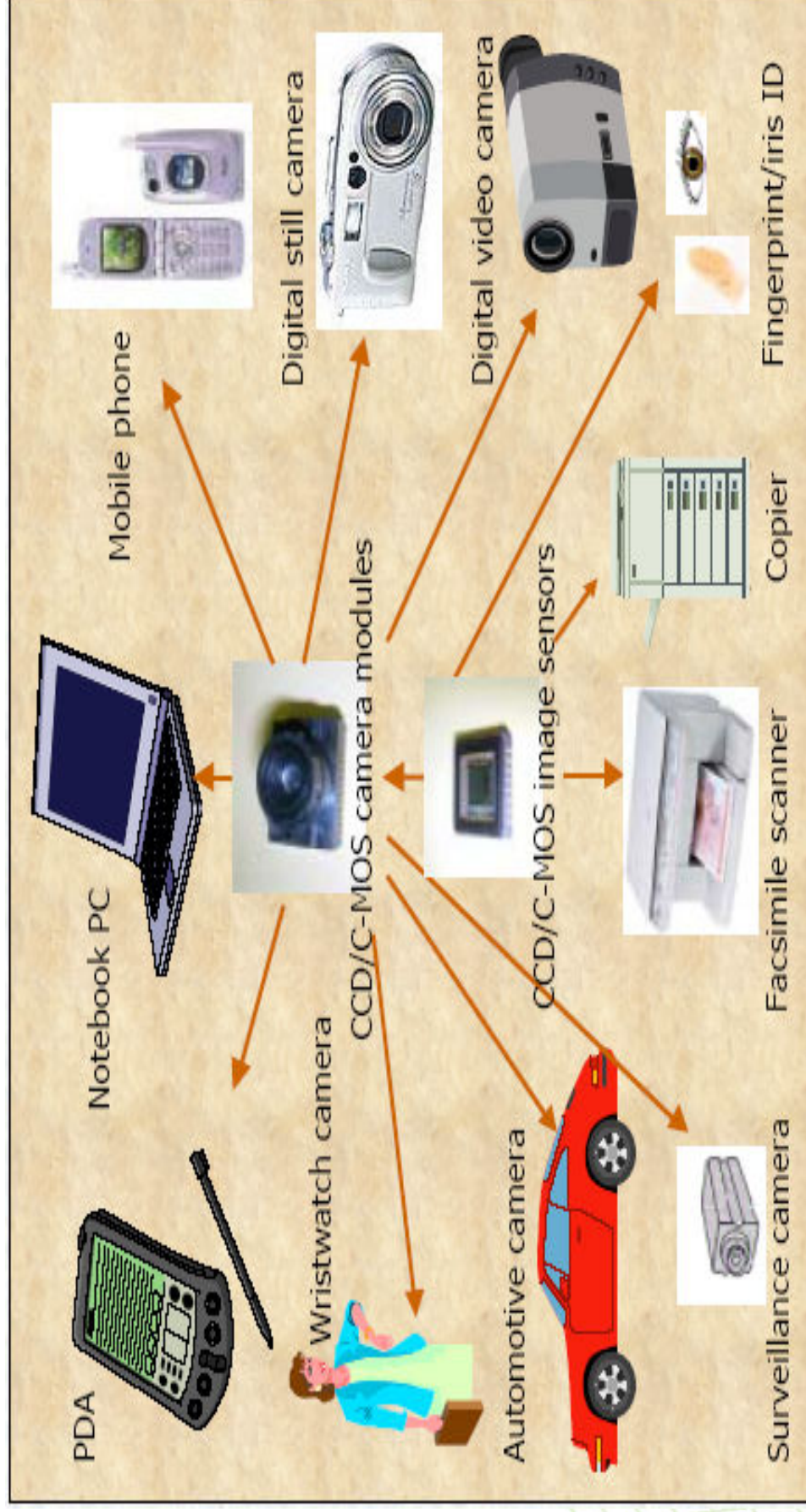

Consumer -, communication -, security management -, QA -, Automotive -, and Personal management tools...etc are using the CIS IC in our daily lives.



YoungTek Electronics Corp.

Auto Optical Inspection (自動光學檢測系統)

Company Profile

YT 2200 REEL TYPE COMPONENTS AOI system

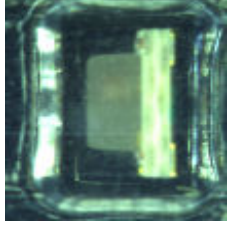
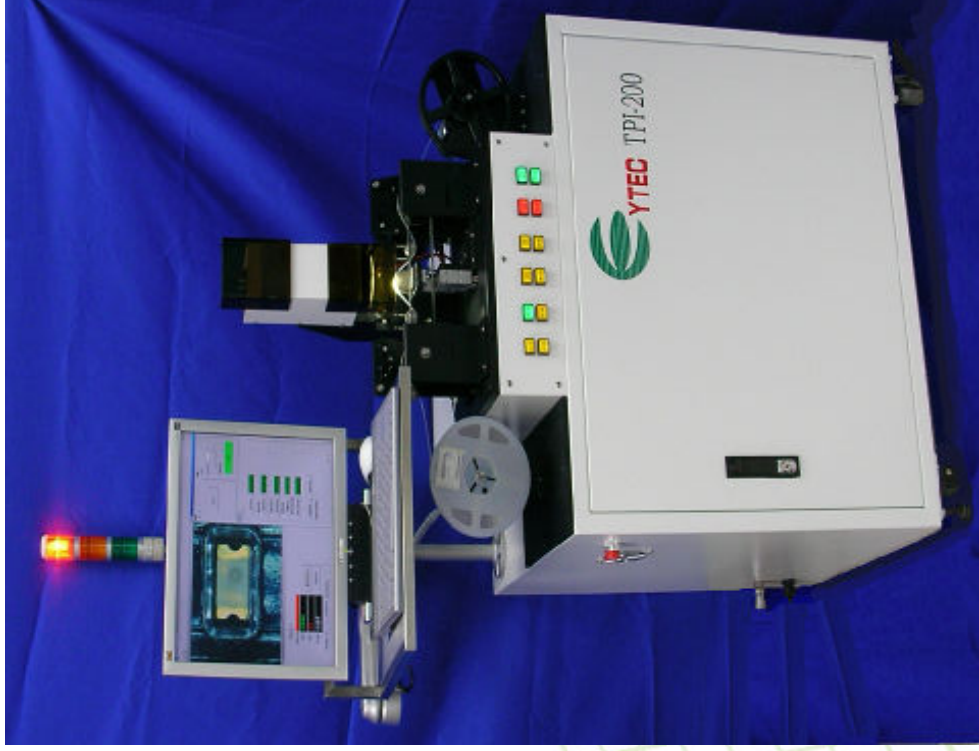

Tilt

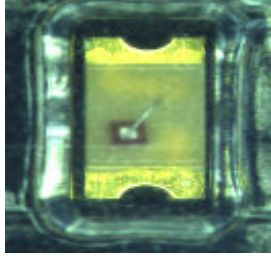

Polarity inverse package

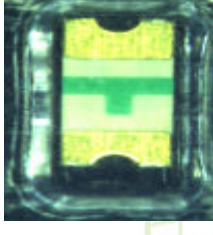

Over turn

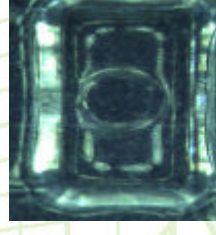

Empty

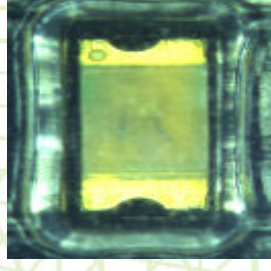

Mixed package



YoungTek Electronics Corp.

Auto Optical Inspection Application

Company Profile

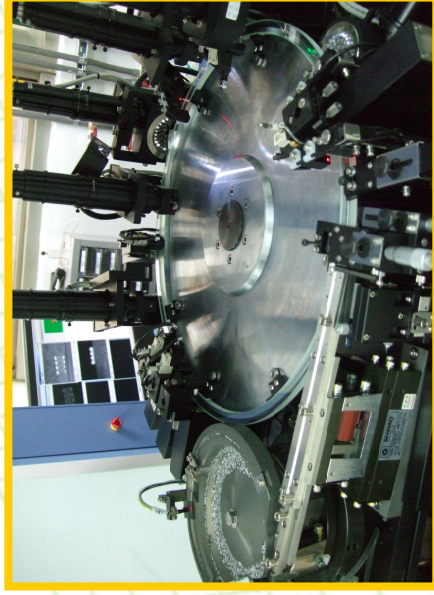
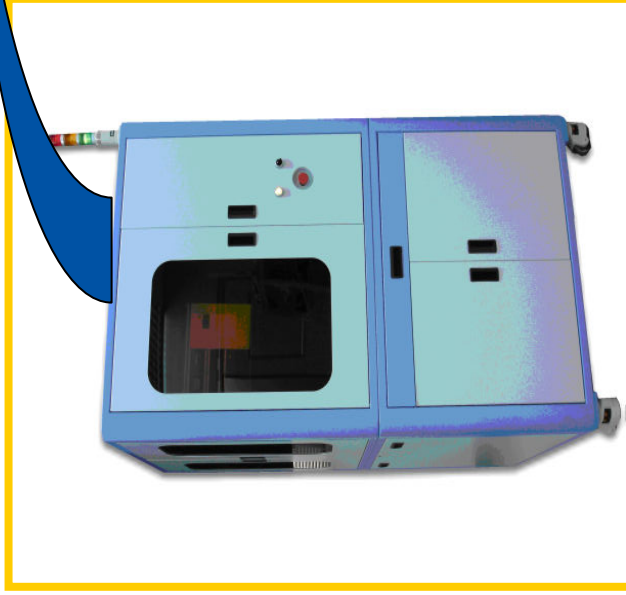

Reel type taped products:

- Resistor
- Capacitor
- Inductor
- LED
- IC
- Relay
- Connector
- Fuse





Revenue Growth & Business Expansion Review

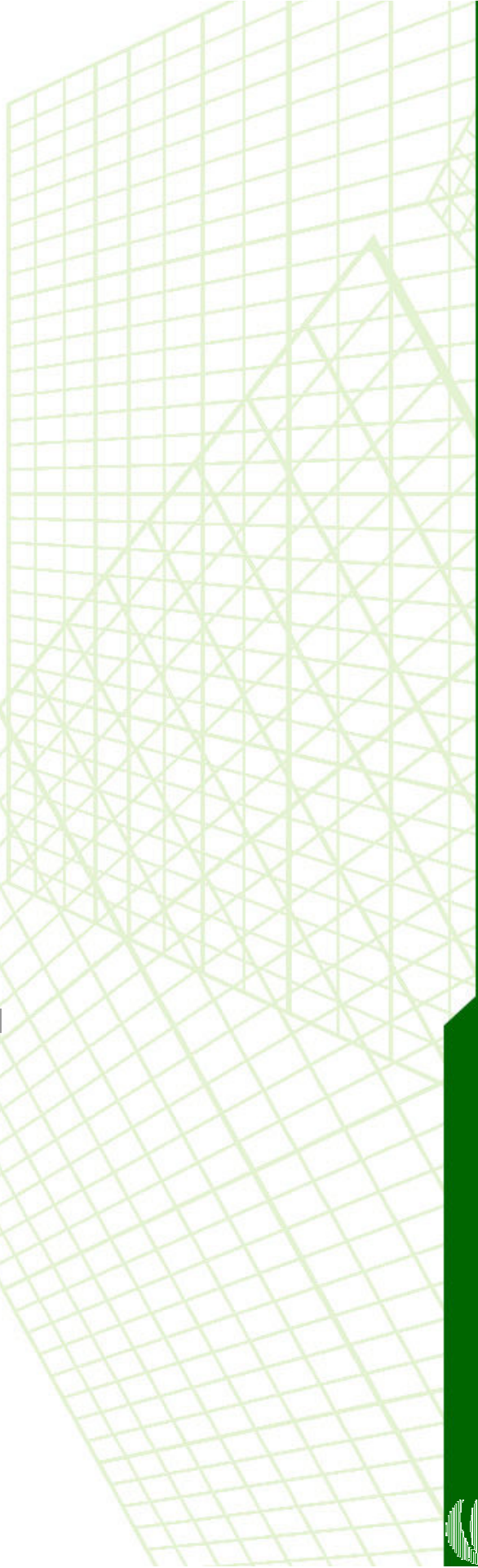

2009&2010 Monthly Revenue

Company Profile
NT\$(Thousand)

Business Item/Month	Jan.	Feb	Mar	Apr	May	Jun.	Jul.	Aug.	Sep.	Oct.	Nov.	Dec.	Total	Share(%)	
切割拋檢代工 Sawing & Sorting OEM	2009	25,665	40,289	54,376	61,140	71,468	77,964	92,179	92,277	89,220	84,948	93,082	417,077	46.16%	
	2010	87,489	88,907	88,243	90,674	100,946	114,676	121,262					692,197	43.23%	
	YoY	240.89%	120.67%	62.28%	48.31%	41.25%	47.09%	40.72%					65.96%		
	MoM	-6.01%	1.62%	-0.75%	2.75%	11.33%	13.60%	5.74%							
測試代工 Testing OEM	2009	27,681	33,471	51,839	62,960	73,907	82,856	82,376	95,383	88,814	82,815	84,392	420,063	46.49%	
	2010	84,827	73,814	106,873	100,877	102,290	111,242	116,253					696,176	43.48%	
	YoY	206.44%	120.53%	106.16%	60.22%	38.40%	34.26%	33.09%					65.73%		
	MoM	0.52%	-12.98%	44.79%	-5.61%	1.40%	8.75%	4.50%							
機器組裝等產品銷售 Own Product Sales	2009	2,666	5,496	9,529	7,812	7,505	27,554	8,578	86,434	71,320	6,554	23,240	66,404	7.35%	
	2010	11,188	10,261	31,037	34,892	39,340	48,127	37,907					212,752	13.29%	
	YoY	319.65%	86.70%	225.71%	346.65%	424.18%	74.66%	548.87%					220.39%		
	MoM	-51.86%	-8.29%	202.48%	12.42%	12.75%	22.34%	-21.24%							
營業收入淨額 (Unit:K) Sales Revenue (Net)	2009	56,012	79,256	115,744	131,912	152,880	188,374	183,133	274,094	249,354	174,317	200,714	903,544	100.0%	
	2010	183,504	172,982	226,153	226,443	242,576	274,045	275,422					1,601,125	100.0%	
	YoY	227.62%	118.26%	95.39%	71.66%	58.67%	45.48%	53.55%					77.20%		
	MoM	-8.57%	-5.73%	30.74%	0.13%	7.12%	12.97%	0.50%							
營業收入淨額(美元) 計 Sales Revenue (Total)	2009	56,012	135,268	251,012	382,924	535,804	724,178	1,086,677	1,360,771	1,610,125	1,784,442	1,985,156	--	--	
	2010	183,504	356,486	582,639	809,082	1,051,658	1,325,703	1,601,125					837,140	--	
	YoY	227.62%	163.54%	132.12%	111.29%	96.28%	83.06%	77.20%					1,388,373		
	MoM	-2.91%	-5.57%	19.91%	-1.85%	6.10%	11.16%	5.13%					65.85%		
總計代工成長 OEM Growth (Total)	2009	53,346	73,760	106,215	124,100	145,375	160,820	174,555	187,660	178,034	167,763	177,474	837,140	--	
	2010	172,316	162,721	195,116	191,551	203,236	225,918	237,515					1,388,373		
	YoY	223.02%	120.61%	83.70%	54.35%	39.80%	40.48%	36.88%					65.85%		
	MoM	-2.91%	-5.57%	19.91%	-1.85%	6.10%	11.16%	5.13%							



2009/2010 Monthly Revenue Growth

Company Profile

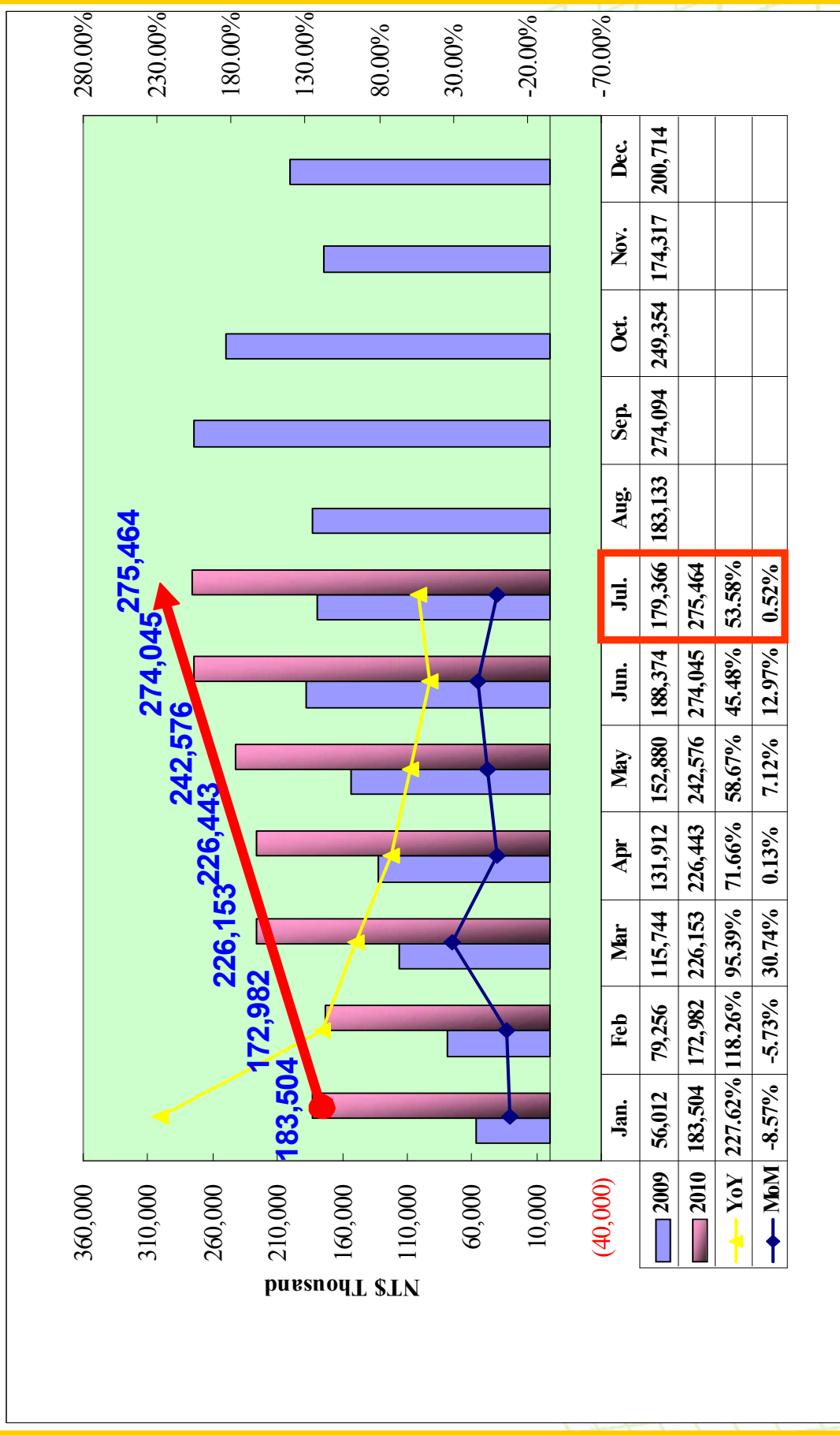

Yearly Net Income & EPS

Company Profile

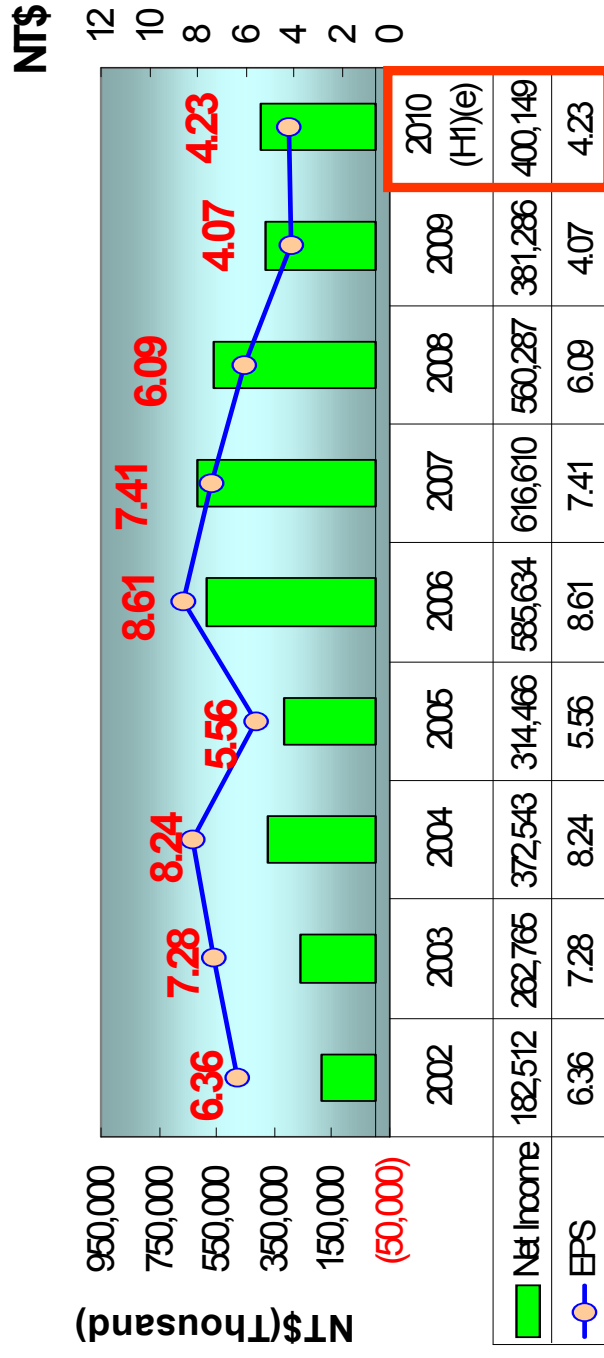

Business Expansion Status(相關產業之狀況)

Company Profile

- 半導體及光電切挑代工服務：2010年Q1業績YOY成長120%創歷史Q1當季之新高、Q2業績YOY成長45.5%、QOQ成長15.7%創歷史單季及上半年新高、進入七月份業績YOY成長40.7%、MOM成長5.7%創歷史單月新高、現階段觀察客戶八月份需求、仍持續維持在高檔、因此將持續追蹤、另LED在新的應用提昇下樂觀預期在LED挑檢已擴充之產能應可適時提供市場成長之需求、相信可挹助公司之營收成長。
- IC測試系統開發：2006年3月份與美商安捷倫(Agilent)科技(新公司名稱: Verigy惠瑞捷)簽訂IC測試系統技術合作、除了2006年已陸續支付久元簽約金而達成階段性目標、因而提昇公司營收和獲利。另在雙方合作互動下已提昇測試機技術層次及銷售量、更上層樓。
- CIS、CCM及AOI設備開發：成功開發完成CIS(CMOS影像感測系統)、具備高速影像處理及完整電性測試之解決方案、並導入代工服務、挹助營收。另自行開發之CCM(影像感測模組測試設備)及AOI(自動光學檢測系統)等設備，目前已取得部份訂單且陸續交機中、AOI設備研發係以解決半導體及光電等產業在目檢之視覺盲點並可大幅節省人力、並已將光電技術結合影像分析等與自動化設備設計、成功研發出各類型外觀檢測機、在大環境逐漸回溫之際、2009年下半年起已感受到需求動力,統計全年YOY成長28.3%明顯高於預期、今2010年Q1業績YOY成長197%創歷史Q1當季之次高、Q2業績YOY成長185%MOM成長133%創歷史上半年之次高進入七月份業績YOY成長549%、創歷史七月份之當月新高、現階段觀察客戶Q3狀況需求持續往上、相信在持續開發新產品及功能提昇下、展望未來應可持續挹助業績成長之動力。
- 半導體代工服務：2010年Q1業績YOY成長135%、QOQ成長3.7%創歷史Q1當季之新高、Q2業績YOY成長43.1%、QOQ成長18.4%創歷史單季及上半年新高、進入七月份業績YOY成長33.1%、MOM成長4.5%創歷史單月新高、現階段觀察客戶八月份需求、仍持續維持在高檔、因此將持續追蹤、而YTEC在持續開發新產品與互補及平衡的產品線發酵下(如LCD,CIS.....etc)、展望未來應可持續挹助業績成長之動力。



Share payout composition and history

Company Profile

Year	九十二年度 (2003)	九十三年度 (2004)	九十四年度 (2005)	九十五年度 (2006)	九十六年度 (2007)	九十七年度 (2008)	九十八年度 (2009)	九十九年度 (2010)
	分派十一年 Profit(2002)	分派十二年 Profit(2003)	分派十三年 Profit(2004)	分派十四年 Profit(2005)	分派十五年 Profit(2006)	分派十六年 Profit(2007)	分派十七年 Profit(2008)	分派十八年 Profit(2009)
Cash(NID)	200	300	300	261	399	400	300	300
Free stock of	200	200	200	087	100	050	010	010
stock Capital reserve fund	-	-	-	-	-	-	-	-
ERS(NID)	636	728	824	556	861	741	609	407



公司願景Company Mission

Company Profile

著眼於國內外市場的開拓，讓久元成爲立足台灣的整合性後段IC代工服務廠，並朝放眼世界的自有產品、自有品牌邁進。

Based on the domestic and international marketing development, YTEC has gotten a foothold as an integrated back-end IC OEM factory. YTEC moves forward, with it's own products, and Own Bench Marks.

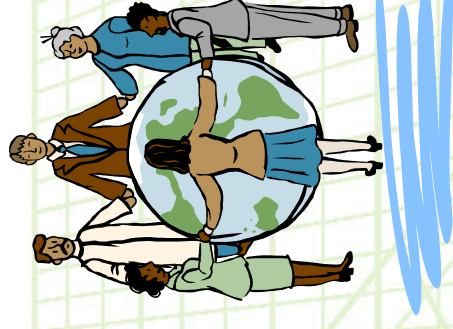

YTEC YoungTek Electronics Corp.

Q & A

Company Profile

Thank you very much



YoungTek Electronics Corp.